

PART 5: (WATER SUPPLY)

PART 5 (WATER SUPPLY)

Purpose

The purpose of the Part 5 (Water Supply) is to provide for:

- The protection of the water supply;
- The conditions of supply of water by the Council;
- Provision through schedules of standards for connection to the water supply system of the Council;

Part 5 (Water Supply) is part of the Hauraki District Council Consolidated Bylaw. Part 1 (Introduction) of the Consolidated Bylaw contains provisions that apply to Part 5 (Water Supply) by providing generally applicable definitions, administrative measures and enforcement measures.

1.0 INTRODUCTION

1.1 SCOPE

The purpose of Part 5 (Water Supply) of the Bylaw is to enable the Council as Water Supply Authority, to provide for the supply of water to its customers.

1.2 TITLE

This Part shall be known and cited as the Part 5 (Water Supply) of the Hauraki District Council Consolidated Bylaw 2007 and shall come into operation on the date specified by public notice after the Hauraki District Council makes this Bylaw. For expediency this Part of this Bylaw may be referred to in this or other Parts of this Bylaw as Part 5 (Water Supply)

1.3 ENABLING ENACTMENTS

This Part of this Bylaw is made pursuant and subject to:

- (a) Building Act 2004 and Regulations;
- (b) Building Regulations 1992 (including the New Zealand Building Code);
- (c) Fire Service Act 1975;
- (d) Health Act 1956 and regulations;
- (e) Local Government Act 1974;
- (f) Local Government Act 2002;
- (g) Local Government (Rating) Act 2002;
- (h) Plumbers, Gasfitters and Drainlayers Act 1976;
- (i) Plumbers, Gasfitters and Drainlayers Act 2006;
- (j) Resource Management Act 1991; and
- (k) Water Supplies Protection Regulations 1961
- (l) Other applicable enactments

1.4 LIST OF SCHEDULES PASSED IN TERMS OF PART 5

Schedule 1: Examples of point of supply location for Figure 1

Schedule 2: Examples of point of supply location for Figure 2

Schedule 3: Schedule 3: Codes and Standards and Sources of Reference

1.5 ADOPTION, AMENDMENT AND REVOCATION OF SCHEDULES

The Council may from time to time adopt, amend or revoke by resolution the Schedules of this Part of the Bylaw listed in clause 1.4

1.6 DEFINITIONS AND INTERPRETATION

For the purposes of this Part the following definitions shall apply:

ADEQUATE SUPPLY has the same meaning as in section 69G of the Health (Drinking Water) Amendment Act;

AIR GAP SEPARATION means a minimum vertical air gap between the outlet of the water supply fitting which fills a storage tank, and the highest overflow water level of that storage tank;

BACKFLOW means a flow of water or other liquid through any service pipe or supply pipe in a reverse direction to the normal supply flow;

CUSTOMER means a person who uses, or has obtained the right to use or direct the manner of use of water supplied by the Council to any premises;

CONDITIONS OF SUPPLY means the terms and conditions determined by the Council in accordance with section 3 of this Part of the Bylaw;

DETECTOR CHECK VALVE is a check (non-return) valve which has a positive closing pressure and a metered bypass to measure flows typically associated with leakage or unauthorised use on a dedicated fire supply;

EXTRAORDINARY SUPPLY means a category of 'on demand supply' and includes all purposes for which water is supplied other than ordinary supply and may be subject to specific conditions and limitations, including restricted flow supply;

FEES AND CHARGES means the list of items, terms and prices for services associated with the supply of water as adopted by the Council in accordance with section 150 and 151 of the Local Government Act 2002;

FIREFIGHTER means an appropriately trained person assessing the water supply systems for fire fighting capability, and accessing them for the purpose of fighting a fire;

LEVEL OF SERVICE means the measurable performance standards on which the Council undertakes to supply water to its customers;

ON DEMAND SUPPLY means a supply which is available on demand directly from the point of supply subject to the agreed level of service;

ORDINARY SUPPLY means a category of on demand supply and is the supply of water to a customer which is used solely for domestic purposes;

POINT OF SUPPLY to an individual customer is the point on the service pipe which marks the boundary of responsibility between the customer and the Council, irrespective of property boundaries;

POTABLE has the same meaning as in section 69G of the Health (Drinking Water) Amendment Act;

PREMISES include the following:

- (a) A property or allotment which is held under a separate certificate of title or for which a separate certificate of title may be issued; or
- (b) A building that has been defined as an individual unit by a cross-lease, unit title or company lease and for which a certificate of title is available; or
- (c) A buildings and dwelling houses to which a separate supply of water is provided;
- (d) Land held in public ownership (e.g. reserve) for a particular purpose;

RESTRICTED FLOW SUPPLY means where a small continuous flow is supplied by a flow control device, and storage is provided by the customer to cater for the customer's demand fluctuations.

RESTRICTOR means a control device fitted to the service pipe to regulate the flow of water to a customer's premises.

ROADING AUTHORITY means either the Council or Transit New Zealand.

RURAL WATER SUPPLY AREA means an area formally designated by the Council as an area serviced by a reticulated water supply system that is intended to supply water for specified purposes via restricted flow supplies and/or on demand supplies but not necessarily with a fire fighting capability;

SERVICE PIPE means that section of water pipe between a watermain and the point of supply, and owned and maintained by the Council;

SERVICE VALVE or TOBY means the valve at the end of the service pipe;

STORAGE TANK means any tank having a free water surface used for the storage of potable water;

SUPPLY PIPE means that section of pipe between the point of supply and the customer's premises through which water is conveyed to the premises, and owned and maintained by the customer;

TARGETED RATES has the same meaning as in section 2 of the Local Government (Rating) Act 2002;

URBAN WATER SUPPLY AREA means an area formally designated by a Council as an area serviced by a reticulated water supply system that is intended to supply water to customers via on demand supplies with a fire fighting capability;

WATER SUPPLY AUTHORITY means the Council, including its authorised agents;

WATER SUPPLY SYSTEM means all the components of the network from the point of abstraction which form the natural environment to the point of supply. This includes but is not limited to: wells, infiltration galleries, intake structures, open raw and treated water storage ponds/lakes, falling mains, treatment plants, raw and treated water reservoirs, trunk mains, service mains, rider mains, pump stations and pumps, valves, hydrants, service pipes, boundary assemblies, meters, backflow preventers and tobies;

WATER UNIT One water unit equals 450 litres per hectare per day, and is the basis of measurement for a restricted flow supply;

2.0 PROTECTION OF WATER SUPPLY

2.1 WATER SUPPLY SYSTEM

2.1.1 ACCESS TO SYSTEM

No person other than the Council and its authorised agents shall have access to any part of the water supply system, except to connect to the point of supply, subject to clause 3.1, and to operate the service valve.

2.1.2 NO PERSON TO CONNECT TO OR INTERFERE WITH A WATER SUPPLY SYSTEM

Except as set out in clauses 2.1.1, 2.1.3 and 2.1.4, no person shall make any connection to or otherwise interfere with any part of the water supply system.

2.1.3 FIRE

The right to gain access to, and draw water from fire hydrants for the purpose of fighting fires shall be restricted to fire fighters.

2.1.4 OTHER USES

The right to gain access to, and draw water from the water supply for uses other than fire fighting shall be restricted to:

- (a) the Council or its agents;
- (b) permit holders: Those persons who after having submitted an application to the Council are subsequently approved to draw water from fire hydrants or tanker filling points. Such permits are valid only so long as the permit holder complies with the conditions endorsed on the permit.

2.1.5 WORKING AROUND BURIED SERVICES

The following shall apply:

- (a) The Council shall keep accurate permanent records (as-built) of the location of its buried services, where these are known. This information shall be available for inspection (with copies available if required), at no cost to the users. Charges may be levied to cover the costs of making copies available.
- (b) Any person proposing to carry out excavation work shall view the records referred to in clause (a) (as-built information) to establish whether or not Council services are located in the vicinity. At least ten working days notice in writing shall be given to the Council of an intention to excavate in the vicinity of its services. Where appropriate the Council will mark out to within ± 0.5 m on the ground the location of its services, and may nominate in writing any restrictions on the work it considers necessary to protect its services. The Council may charge for this service.
- (c) When excavating and working around buried services due care shall be taken to ensure the services are not damaged, and that bedding and backfill is reinstated in accordance with the appropriate Council specification. Excavation within roadways is also subject to the permit process of the appropriate roading authority.
- (d) Any damage which occurs to a Council service shall be reported to the Council immediately. The person causing the damage shall reimburse the Council with all costs associated with repairing the damaged service, and any other costs the Council incurs as a result of the incident.

2.2 PROTECTION OF SOURCE WATER

2.2.1 CATCHMENT CLASSES

- (a) Catchment areas from which untreated water is drawn for the purposes of water supply are divided into the following classes:
 - i) Controlled;
 - ii) Restricted;
 - iii) Open.

These may apply to both surface water and/or groundwater catchments.

- (b) The provisions of section 2 of Part 3 (Public Safety) relating to public places shall apply to catchment areas.

2.2.2 CONTROLLED CATCHMENTS

- (a) Catchment areas which are designated as controlled, or any area held by the Council as a water reserve, shall not be entered by any person except those specifically authorised or permitted in writing by the Council.
- (b) Entry permits shall forbid, regulate or control the following activities:
 - i) Hunting, trapping, shooting or fishing;
 - ii) Lighting or maintaining any fire;
 - iii) Taking any dog;
 - iv) Damaging or destroying any trees, shrubs, or other existing cover, or interference with any property;
 - v) Carrying of any firearm or weapon of any kind, any trap or any fishing gear which may be used for the hunting or catching of birds, fish or animals; or
 - vi) Use of any pesticide or toxic substance for any purpose whatsoever.
- (c) Inspection of permits includes:
 - i) No person to whom any permit has been issued shall enter any controlled catchment area or land held by the Council as a water reserve without presenting such a permit for inspection by an authorised officer and notifying the authorised officer of their intention of entering such an area as the case may be.
 - ii) Every person on any controlled catchment area or land held by the Council as a water reserve shall upon demand produce any such permit for inspection by an authorised officer.
 - iii) No permit issued shall be capable of being transferred.
 - iv) The Council may at any time, by notice in writing delivered to the holder, revoke or suspend any such permit for such time as shall be stated in such notice.
- (d) In any controlled catchment area or any land held by the Council as a water reserve:
 - i) No person whether holding any permit issued under the provisions of this Part of this Bylaw or not (other than a duly appointed officer of the Council), shall commit or cause or permit to be committed any act which

may interfere with or be likely to interfere with the free and lawful exercise of any rights vested in any other person in any such area.

- ii) Every person shall upon the request of an authorised officer of the Council immediately leave the controlled catchment area or land held by the Council as a water reserve, but shall nevertheless be liable also to be prosecuted for the breach of any of the provisions of this Part of this Bylaw, and the failure so to leave shall constitute a further offence.

2.2.3 RESTRICTED CATCHMENTS

Catchment areas which are designated as restricted shall allow for certain activities, but shall be as for controlled catchments for other activities. Activities which will be allowed may include unrestricted entry for:

- (a) Tramping;
- (b) Hunting;
- (c) Trapping;
- (d) Shooting;
- (e) Fishing.

2.2.4 OPEN CATCHMENTS

Catchment areas which are designated as open will not restrict or control activities which may occur. However in the event of a spillage, or other event which has released or is likely to release hazardous substances into the waters of the catchment, the Council shall be advised of the details with due urgency. This requirement shall be in addition to those other notification procedures which are required for other authorities.

3.0 CONDITION OF SUPPLY

3.1 APPLICATION FOR SUPPLY

3.1.1 INITIAL APPLICATION

- (a) Every application for a supply of water shall be made in writing on the relevant standard Council form together with the prescribed charges. The applicant shall provide all the details required by the Council.

- (b) On receipt of an application the Council shall, after consideration of the matters in clause 3.5, either:
 - i) Approve the application and inform the applicant of the type of supply, the size of the connection, any particular conditions applicable, and the general conditions of supply (including level of service) under which water will be supplied; or
 - ii) Refuse the application and notify the applicant of the decision giving the reasons for refusal.
- (c) For the agreed level of service to the applicant, the Council will determine the sizes of all pipes, fittings and any other equipment, up to the point of supply. The Council will supply and install the service pipe up to the point of supply at the customer's cost; or may allow the supply and installation of the service pipe to be carried out by approved contractors.
- (d) The applicant must have the authority to act on behalf of the owner of the premises for which the supply is sought, and shall produce written evidence of this if required.
- (e) An approved application for supply which has not been actioned within 6 months of the date of application will lapse unless otherwise approved. Any refund will be at the discretion of the Council.

3.1.2 CHANGE OF USE

Where a change in the level of service or end use of water supplied to premises occurs, and/or the supply changes from an ordinary to an extraordinary type as provided for in clause 3.5 or vice versa, a new application for supply shall be required.

3.2 POINT OF SUPPLY

3.2.1 SINGLE OWNERSHIP

The point of supply shall be:

- (a) For individual customers the point of supply shall be located as shown in Type 2 (Examples 1,2 and 3) and Type 1 or 2 (Example 4) of Schedule 1, Figure 1 of this Part of the Bylaw or as close as possible where fences, walls or other permanent structures make it difficult to locate it at the required position. Other positions shall require specific approval.

- (b) For each individual customer there shall only be one point of supply, unless otherwise approved.
- (c) The typical layout at a point of supply is shown in Schedule 2, Figure 2 of this Part of the Bylaw.
- (d) The Council gives no guarantee as to the serviceability of the valve located on the service pipe. Where there is no customer stopcock, or where maintenance is required between the service valve and the customer stopcock, the customer may use the service valve to isolate the supply. However the Council reserves the right to charge for maintenance of this valve if damaged by such customer use.

3.2.2 MULTIPLE OWNERSHIP

The point of supply for the different forms of multiple ownership of premises and/or land shall be:

- (a) For company share/block scheme (body corporate) as for single ownership.
- (b) For leasehold/tenancy in common scheme (cross lease), strata title, and unit title (body corporate) - each owner shall have an individual supply with the point of supply determined by agreement with the Council. In specific cases other arrangements may be acceptable subject to individual approval.

For a multiple ownership supply which was in existence prior to the coming into effect of the conditions of supply, the point of supply shall be the arrangement existing at that time, or as determined by agreement with the Council for an individual case.

3.3 ACCESS TO AND ABOUT POINT OF SUPPLY

3.3.1 RIGHTS OF ACCESS

The following times of access apply:

- (a) Where the point of supply is on private property the customer shall allow the Council access to, and about the point of supply between 7.30 am and 6 pm on any day for:
 - i) Meter reading without notice;
 - ii) Checking, testing and maintenance work with notice being given whenever possible.

- (b) Outside these hours (e.g. for leak detection) the Council will give notice to the customer in accordance with section 171 of the Local Government Act 2002;
- (c) Under emergency conditions the customer shall allow the Council free access to, and about the point of supply at any hour in accordance with section 173 of the Local Government Act 2002;
- (d) Where access is not made available for any of the above and a return visit is required by the Council, a rate in accordance with the “Meter reading by appointment” item may be charged.

3.3.2 MAINTENANCE OF ACCESS

The customer shall maintain the area in and around the point of supply free of soil, growth, or other matter or obstruction which prevents, or is likely to prevent convenient access.

3.4 TYPES OF SUPPLY *

3.4.1 ORDINARY SUPPLIES

For ordinary supplies domestic purposes shall include the use of a hose for:

- (a) Washing down a car, boat etc;
- (b) Garden watering by hand;
- (c) Garden watering by a portable sprinkler (subject to the provisions of clause 3.6.3);
- (d) Fixed garden irrigation systems;
- (e) Domestic fire sprinkler systems;
- (f) Ornamental fish ponds;

3.4.2 EXTRAORDINARY SUPPLIES

For extraordinary supplies permitted uses shall include:

- (a) Domestic – spa or swimming pool in excess of 10 m3 capacity,
- (b) Commercial and business;
- (c) Industrial;
- (d) Agricultural;

* The Council shall provide water in accordance with the level of service contained in the Long Term Council Community Plan. For those periods where the level of service allows non-compliance with the specified value, the Council will make every reasonable attempt to achieve the specified value.

- (e) Horticultural;
- (f) Viticulture;
- (g) Lifestyle blocks;
- (h) Fire protection systems;
- (i) Out of district;
- (j) Temporary supply;
- (k) Any other use specified by the Council from time to time by publicly notified resolution.

3.4.3 ON DEMAND SUPPLY

- (a) Water shall be supplied to every premises that is entitled to an ordinary supply of water, subject to:
 - i) The premises lying within a water supply area if such an area has been constituted by the Council; and
 - ii) The exclusion of its use under any restrictions made and publicly notified by the Council under clause 3.5.3; and
 - iii) Payment of the appropriate charges in respect of that property; and
 - iv) The conditions of supply, and
 - v) Any other charges or costs associated with subdivision or development.
- (b) The Council shall be under no obligation to provide an extraordinary supply of water, (refer also to the provisions of clauses 3.6 and 3.8.2)

3.4.4 METERING

Both ordinary and extraordinary supplies of water shall normally be metered and levied as rates as prescribed in the Local Government (Rating) Act 2002, Part 1, sections 9, 15 to 19 and Part 4, sections 101 to 103.

3.4.5 RESTRICTED FLOW SUPPLY

The following apply:

- (a) Restricted flow shall be available only to premises within a designated area, or under special conditions set by the Council;
- (b) The water supply shall be restricted so as to deliver the agreed number of water units supplied at a steady flow rate;
- (c) The Council shall charge for the restricted flow supply by either:
 - (A) The volume passing through a meter; or

- (B) The agreed number of water units.
- (d) Restricted flow shall be available only to premises that have storage tanks capable of containing an adequate supply of water for at least 24 hours.

3.5 CONTINUITY OF SUPPLY†

3.5.1 UNINTERRUPTED SERVICE

If a customer has a particular requirement for an uninterrupted level of service (flow, pressure or quality), it will be the responsibility of that customer to provide any necessary storage, back up facilities, or equipment.

3.5.2 DEMAND MANAGEMENT ‡

- (a) The customer shall comply with any restrictions on the use of water to manage high seasonal or other demands that may be approved by the Council pursuant to section 151 (2) of the Local Government Act 2002.
- (b) Such restrictions will be publicly notified by the Council.

3.5.3 EMERGENCY RESTRICTIONS

- (a) During an emergency the Council may restrict or prohibit the use of water for any specified purpose, for any specified period, and for any or all of its customers.
- (b) Such restrictions shall be publicly notified by the Council.
- (c) The Council may enact penalties over and above those contained in the conditions of supply to enforce these restrictions.
- (d) The decision to make and lift restrictions, and to enact additional penalties, shall be made by the Council, or where immediate action is required by a duly authorised officer.

†The Council does not guarantee an uninterrupted or constant supply of water, or maintenance of an existing pressure which is in excess of an agreed level of service, but shall do its best to meet the continuity of supply levels of clause 3.5, subject to the exemptions contained in clauses 3.6.3 and 3.6.4. Refer also to clause 3.7.2. Where works of a permanent or temporary nature are planned which will affect an existing supply, the Council will consult with all known customers likely to be substantially affected.

‡ When such restrictions apply the Council will take all practicable steps to ensure that an adequate supply of drinking water is provided to each point of supply.

3.5.4 SCHEDULED MAINTENANCE AND REPAIRS

- (a) Wherever practical the Council will make every reasonable attempt to notify the customer of a scheduled maintenance shutdown of the supply before the work commences.
- (b) Where immediate action is required and this is not practical, the Council may shutdown or reconnect the supply without notice

3.6 FIRE PROTECTION CONNECTION

3.6.1 CONNECTION APPLICATION

- (a) Except for domestic fire sprinkler systems, any proposed connection for fire protection shall be the subject of a separate application to the Council for approval
- (b) Any such connection shall be subject to the conditions of supply.

3.6.2 DESIGN

It shall be the customer's responsibility to ascertain and monitor whether the fire protection supply available is adequate for the intended purpose.

3.6.3 FIRE PROTECTION CONNECTION METERING

The following shall apply:

- (a) In any case where the supply of water to any premises is metered the Council may allow the supply of water for the purposes of fire fighting to be made in a manner which by-passes the meter, provided however that the drawing of water will only be permitted in the following circumstances:
 - i) To systems in which the drawing of water is only possible in connection with the sounding of an automatic fire alarm or the automatic notification of the fire brigade; or
 - ii) Where a Council approved detector check valve has been fitted on the meter bypass.
- (b) Where an unmetered connection has been provided to supply water to a fire protection system this shall be used for no other purpose than fire fighting and testing the fire protection system except where the fire protection system is

[§] Shutdowns shall normally not exceed 8 hours

installed in accordance with New Zealand Standard 4157: 2002 Fire Sprinkler Systems for Houses;

- (c) For a fire connection installed prior to the coming into effect of the conditions of supply which is so constructed or so located that it is likely or possible that water will be drawn from it or from any part of it by any person for purposes other than fire fighting, the Council may install on such a connection a water meter suitable for the purpose.

3.6.4 FIRE HOSE REELS

In any case where the supply of water to any premises is metered, fire hose reels shall be connected only to the metered supply, not to a fire protection connection.

3.6.5 CHARGES

Water used for the purpose of extinguishing fires will be supplied free of charge.

3.7 BACKFLOW PREVENTION

The following shall apply:

- (a) Notwithstanding clause (b) of clause 3.7 the Council may fit a backflow prevention device on the Council side of the point of supply.
- (b) It is the customer's responsibility (under the Health Act 1956, and the Building Act 2004) to take all necessary measures on the customer's side of the point of supply to prevent water which has been drawn from the Council's water supply from returning to that supply. These include:
- i) Backflow prevention either by providing an adequate air gap, or by the use of a backflow prevention device;
 - ii) The prohibition of any direct cross-connection between the Council water supply and
 - (1) Any other water supply (potable or non-potable)
 - (2) Any other water source
 - (3) Any storage tank
 - (4) Any other pipe, fixture or equipment containing chemicals, liquids, gases, or other nonpotable substances.

3.8 COUNCIL EQUIPMENT AND INSPECTION

3.8.1 CARE OF WATER SUPPLY SYSTEM

The customer shall take due care not to damage any part of the water supply system, including but not limited to pipework, valves, meters, restrictors, chambers and backflow prevention devices.

3.8.2 INSPECTION

The provisions of section 181 of the Local Government Act 2002 shall apply to inspections by the Council to determine if the customer is in compliance with the conditions of supply.

3.9 METERS AND FLOW RESTRICTORS

3.9.1 INSTALLATION

The following shall apply:

- (a) Meters for on demand metered supplies, and restrictors for restricted flow supplies, shall be supplied installed and maintained by the Council. These devices shall remain the property of the Council.
- (b) For on demand supplies which are not metered, the Council reserves the right, where it considers water use is unusually high, to fit a meter, at the customers cost, and charge accordingly.

3.9.2 LOCATION

Meters and restrictors shall be located in a position which is readily accessible for reading and maintenance, and if practicable immediately on the Council side of the point of supply, in accordance with the examples in Schedule 2, Figure 2 of this Bylaw.

3.9.3 ACCURACY

A customer who disputes the accuracy of a meter or restrictor may apply to the Council for it to be tested provided that it is not within 3 months of the last test. If the test shows non-compliance with the accuracy requirement adopted by the Council then the customer will not be charged for the test. If the test shows compliance then

the customer shall pay a fee in accordance with the Council current fees and charges.

3.9.4 ADJUSTMENT

- (a) Should any meter, after being tested, be found to register a greater or lesser consumption than the quantity of water actually passed through such a meter the Council shall make an adjustment in accordance with the results shown by such tests backdated for a period at the discretion of the Council but not exceeding 12 months, and the customer shall pay a greater or lesser amount according to such an adjustment.
- (b) Where a meter is under reading by more than 20 % or stopped, the Council reserves the right to charge for the amount of water assessed as having been used over the past billing period, and taking into account any seasonal variations in demand.
- (c) Where a meter is over reading, the Council shall make appropriate adjustments to the customer's invoice(s), based on a period of similar use and backdated or when it is agreed the over reading is likely to have occurred.

3.9.5 ESTIMATING CONSUMPTION

The following shall apply:

- (a) Should any meter be out of repair or cease to register, or be removed, the Council shall estimate the consumption for the period since the previous reading of such meter based on the Council's rates remission policy and the customer shall pay accordingly.
- (b) If metering indicates a significant increase in consumption to a premises, which is established as being caused by a previously unknown leak, the Council may estimate consumption as provided in the rates remission policy, providing that the customer repairs the leak with due diligence.
- (c) Where the seal or dial of a meter is broken, the Council may declare the reading void and estimate consumption as provided above.

3.9.6 INCORRECT ACCOUNTS

The following shall apply:

- (a) Where a situation occurs, other than as provided for in clause 3.10.5, where the recorded consumption does not accurately represent the actual

consumption on a property then the account shall be adjusted using the best information available to the Council. Such errors include, but are not limited to, misreading of the meter, errors in data processing, meters assigned to the wrong account, and unauthorised supplies.

- (b) Provided that where an adjustment is required, in favour of the Council or the customer, this shall not be backdated more than 12 months from the date the error was detected.

3.9.7 PLUMBING SYSTEM

The following shall apply:

- (a) Quick-closing valves, pumps, or any other equipment which may cause pressure surges to be transmitted within the water supply system, or compromise the ability of the Council to maintain its stated levels of service, shall not be used on any piping directly connected to the service pipe. In special circumstances such equipment may be approved by the Council.
- (b) In accordance with the New Zealand Building Regulations the plumbing system shall be compatible with the water supply. Specific features of the Council supply which need to be taken into account are contained in table 1.

Table 1

Feature	Value
Maximum pressure	60 metres head
Minimum pressure	(250 kPa)
Normal operating pressure	350 kPa

3.9.8 PREVENTION OF WASTE

The following shall apply:

- (a) The provisions of section 192 and section 224 of the Local Government Act 2002 shall apply to the waste of water.
- (b) The Council provides water for consumptive use not as an energy source. The customer shall not use water or water pressure directly from the supply for driving lifts, machinery, eductors, generators or any other similar device; unless specifically approved.
- (c) The customer shall not use water for a single pass cooling system or to dilute trade waste prior to disposal, unless specifically approved. Provided that a single pass cooling system may be used without specific approval where the water is not wasted but subsequently used for other purposes .

3.9.9 PAYMENT

The following shall apply:

- (a) The customer shall be liable to pay for the supply of water and related services in accordance with the Council current fees and charges.
- (b) The Council may recover all unpaid water charges as prescribed in the Local Government (Rating) Act 2002, Part 3, sections 57 and 58, and 59 to 82.

3.9.10 TRANSFER OF RIGHTS AND RESPONSIBILITIES

The following shall apply:

- (a) The customer shall not transfer to any other party the rights and responsibilities provided for under the conditions of supply.
- (b) A supply pipe shall serve only one customer, and shall not extend by hose or any other pipe beyond that customer's property.
- (c) In particular and not in limitation of the above any water which the customer draws from the Council supply shall not be provided to any other party without approval of the Council.

3.9.11 CHANGE OF OWNERSHIP

- (a) In the event of a premises changing ownership the Council will automatically record the new owner as being the customer at that premises.
- (b) Where a premises is metered the outgoing customer shall give the Council five working days notice to arrange a final reading.

3.9.12 DISCONNECTION AT THE CUSTOMER'S REQUEST

The customer shall give twenty working days notice in writing to the Council of the requirement for disconnection of the supply.

4.0 PROTECTION AND INFRINGEMENT OFFENCES

4.1 BREACHES OF CONDITIONS OF SUPPLY

- (a) The following are deemed breaches of the conditions to supply water:
 - i) An incorrect application for supply which fundamentally affects the conditions of supply;
 - ii) Failure by the customer to meet and comply with the conditions of supply;

- iii) Failure to meet any obligation placed on the customer under any enactment specified in clause 1.3;
- iv) Frustration of the Council's ability to adequately and effectively carry out its obligations;
- v) An act or omission including but not limited to:
 - (1) Failure to pay the appropriate charges by the due date;
 - (2) Failing to repair a leak, or in any way wilfully allowing water to run to waste or to be misused;
 - (3) The fitting of quick-closing valves, subject to clause 3.9.7;
 - (4) Failing to prevent backflow in accordance with clause 3.7;
 - (5) Failing to comply with water use restrictions or prohibitions introduced by the Council for any specified purpose;
 - (6) Using water or water pressure directly from the supply for driving lifts, machinery, eductors, generators or any other similar device; unless specifically approved by the Council;
 - (7) Using water for a single pass cooling or heating system without subsequent use of the water, or to dilute trade waste prior to disposal, unless specifically approved;
 - (8) Extending by hose or any other pipe a private water supply to any premises beyond those premises;
- (b) In the event of a breach, the Council will serve notice on the customer advising the nature of the breach and the steps to be taken to remedy it.
- (c) If the breach is not rectified, the Council may after five working days after the notice had been served on the customer reduce the flowrate in accordance with section 193(1) of the Local Government Act 2002.
- (d) If the breach is such that the Council is required to disconnect the supply in accordance with section 194 of the Local Government Act 2002, such disconnection will be carried out forthwith .

4.2 INTERFERENCE WITH EQUIPMENT

- (a) Any tampering or interfering with Council equipment, either directly or indirectly, shall constitute a breach.

- (b) Without prejudice to its other rights and remedies, the Council shall be entitled to estimate in accordance with section 3.9.5 and charge for the additional water consumption not recorded or allowed to pass where a meter or restrictor has been tampered with, and recover any costs incurred

In compliance with the provisions of the Local Government Act, 2002 and the Bylaws Act, 1910, this Part of the Bylaw is passed by the Hauraki District Council on 14th November, 2007.

THE COMMON SEAL of the HAURAKI DISTRICT COUNCIL was affixed on this 23rd day of November, 2007 in the presence of

_____ Mayor

_____ Chief Executive



**SCHEDULES OF PART 5
(WATER SUPPLY) OF**

**HAURAKI DISTRICT COUNCIL
CONSOLIDATED BYLAW**

Table of Contents

SCHEDULE 1 OF PART 5 – WATER SUPPLY

EXAMPLES OF POINT OF SUPPLY LOCATION

SCHEDULE 2 OF PART 5 – WATER SUPPLY

EXAMPLES OF LAYOUT OF POINT OF SUPPLY

SCHEDULE 3 OF PART 5 – WATER SUPPLY

CODES AND STANDARDS APPLICABLE TO PART 5

SCHEDULE 1 OF PART 5 – WATER SUPPLY

EXAMPLES OF POINT OF SUPPLY LOCATION

Schedule 1 – Examples of point of supply location for Figure 1

Example 1 – With street frontage

Type 1: Point of supply inside boundary

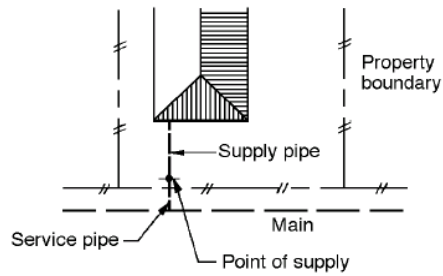

Type 2: Point of supply outside property

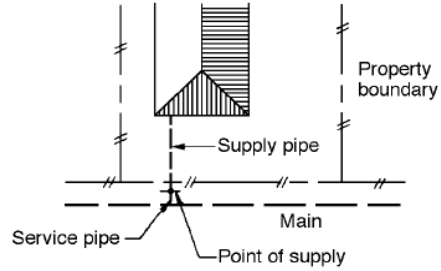

Example 2 – Rear lots on right of way (up to 2 customers)

Type 1: Point of supply inside boundary

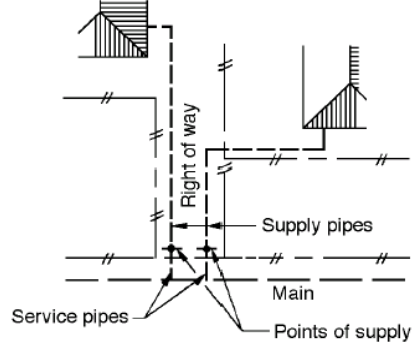

Type 2: Point of supply outside property

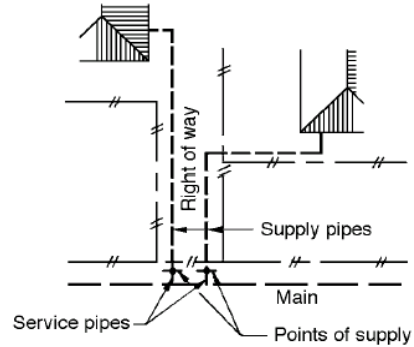

Schedule 1 (continued)

Example 3 – Rear lots on right of way (3 or more customers)

Type 1: Point of supply inside boundary

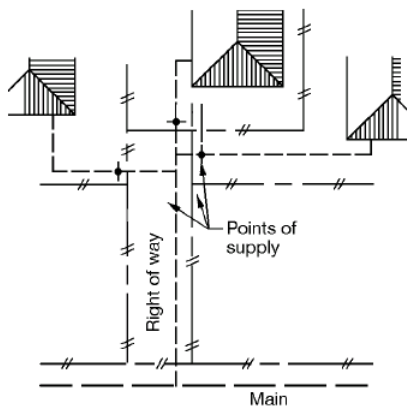

Type 2: Point of supply outside property

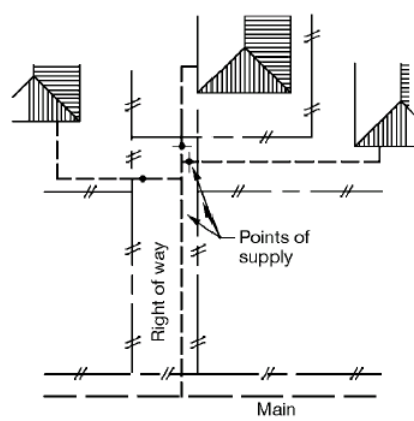

Type 3: Common point of supply

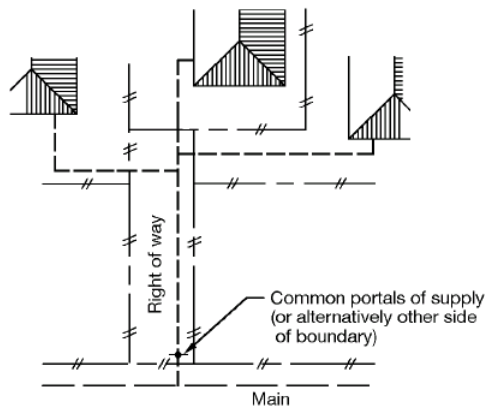

Schedule 1 (continued)

Example 4 – Industrial, commercial, domestic fire and service connections (including schools)

Type 1: Combined fire and service connection

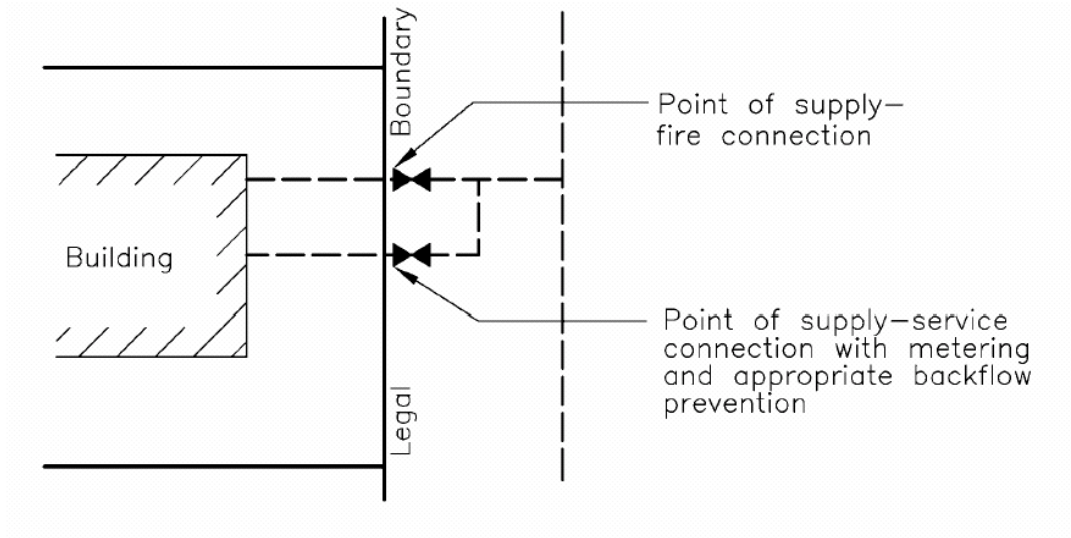

Type 2: Separate fire and service connection

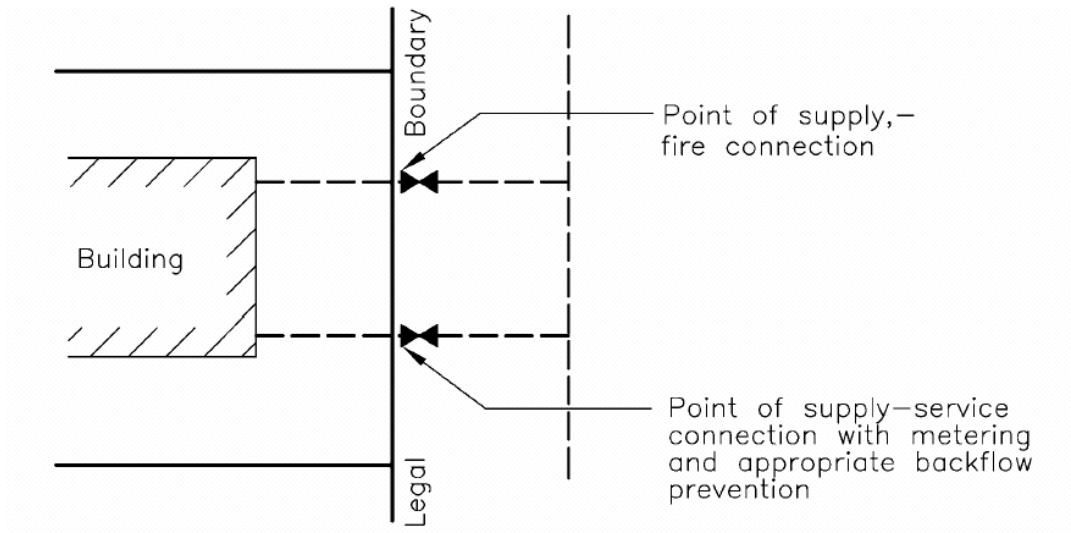

SCHEDULE 2 OF PART 5 – WATER SUPPLY

EXAMPLES OF LAYOUT OF POINT OF SUPPLY

Schedule 2 – Examples of layout at point of supply for Figure 2

Example 5 – Domestic unmetered supply

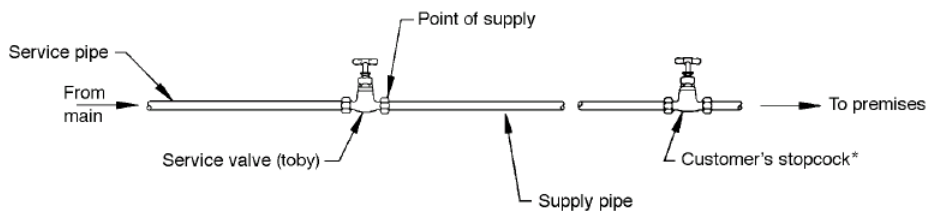

* Provision of New Zealand Building Code Approved Document G12/AS1,
(means of establishing compliance with the Code)

Example 6 – Domestic metered supply

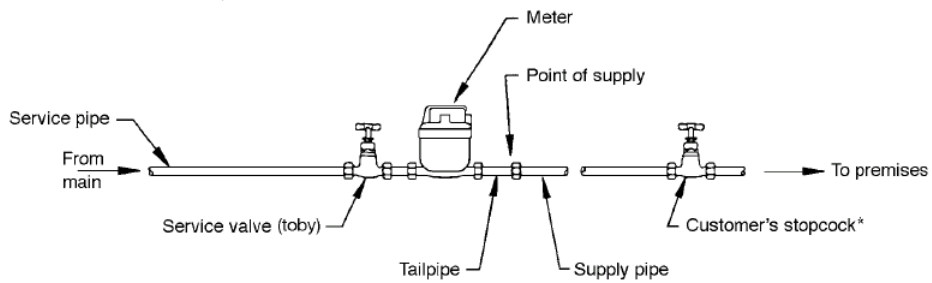

* Provision of New Zealand Building Code Approved Document G12/AS1,
(means of establishing compliance with the Code)

Schedule 2 (continued)

Example 7 – Metered supply with reduced pressure backflow preventer

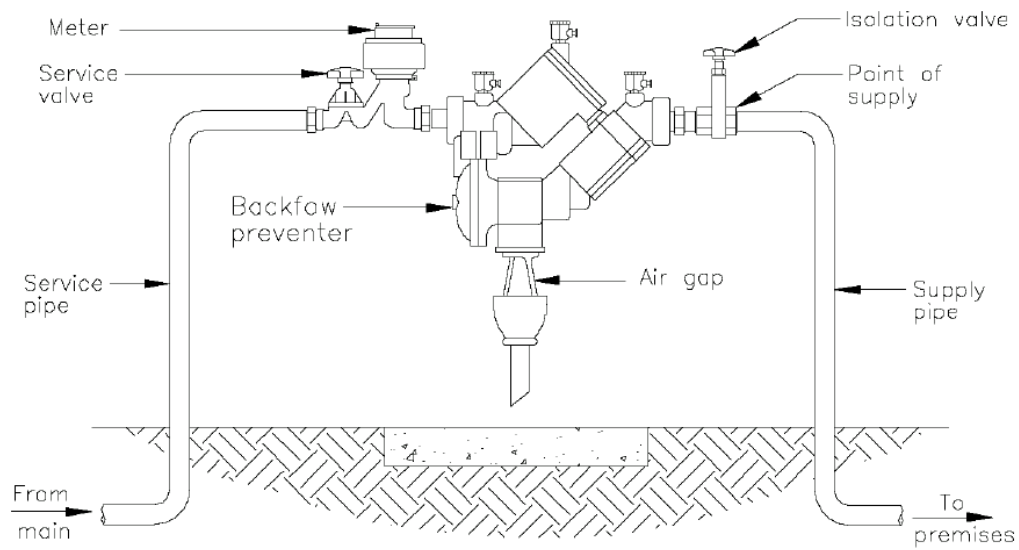

Example 8 – Unmetered supply with vacuum breaker backflow preventer

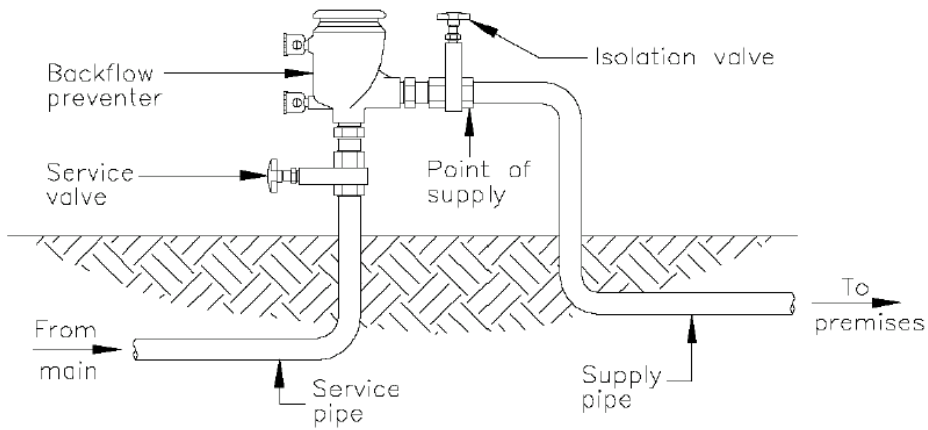

* The building code may require the customer to install additional backflow preventers within the site, which will remain the responsibility of the customer.

SCHEDULE 3 OF PART 5 – WATER SUPPLY

CODES AND STANDARDS APPLICABLE TO PART 5

The Council adopts by resolution the following Codes and Standards to apply as a source of reference to activities regulated by Part 5 of the Bylaw.

a) CODES AND STANDARDS: WATER SUPPLY

REFERENCE	CODES AND STANDARDS	DATE CONFIRMED BY COUNCIL	EFFECTIVE DATE	DATE REVOKED
	Drinking Water Standards for New Zealand 2005			
	BS 5728 <i>Measurement of flow of cold potable water in closed conduits Part 3:1997 Methods for determining principal characteristics of single mechanical water meters.</i>			
	BS EN 14154-3:2005 Water meters. Test methods and equipment.			
	SNZ/PAS 4509:2003 Fire fighting water supplies Code of Practice			
	NZWWA Backflow Code of Practice			
	NZWWA Water Meter Code of Practice			